

THIS DRAWING IS UNPUBLISHED. RELEASED FOR PUBLICATION  
 © COPYRIGHT - By - ALL RIGHTS RESERVED.

| LOC | DIST | REVISIONS |     |                           |           |     |      |
|-----|------|-----------|-----|---------------------------|-----------|-----|------|
| AF  | 50   | P         | LTR | DESCRIPTION               | DATE      | DWN | APVD |
|     |      | W1        |     | REVISED PER ECR-14-004075 | 24MAR2014 | NK  | RL   |

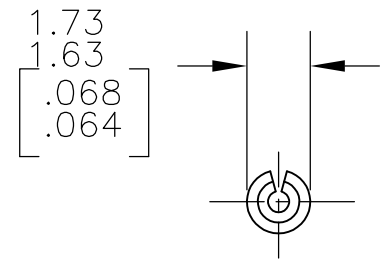

VIEW A-A

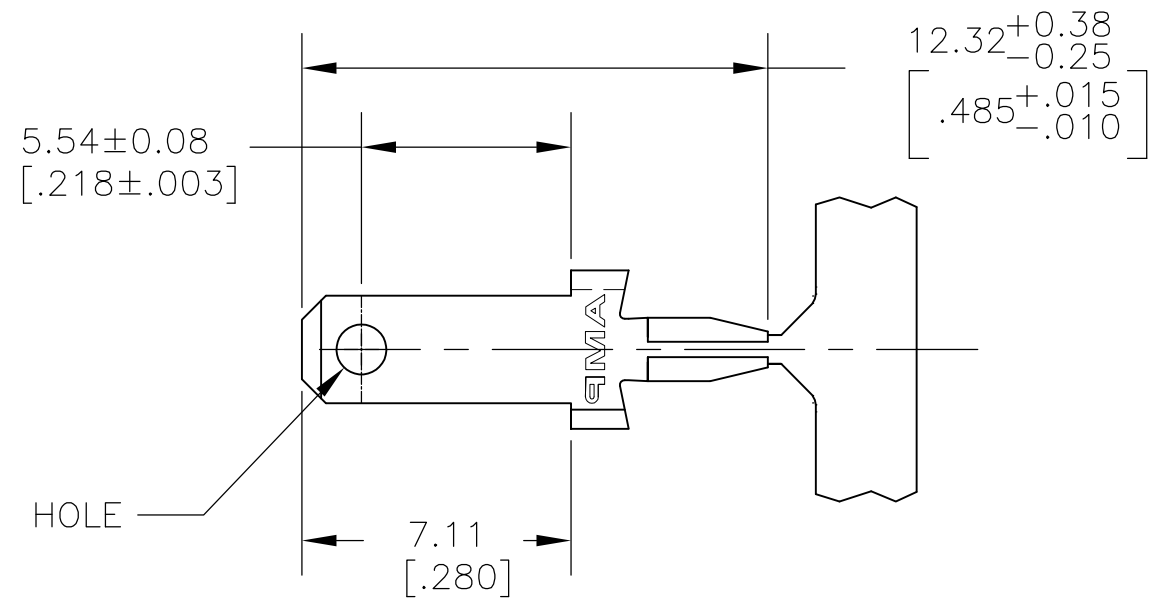
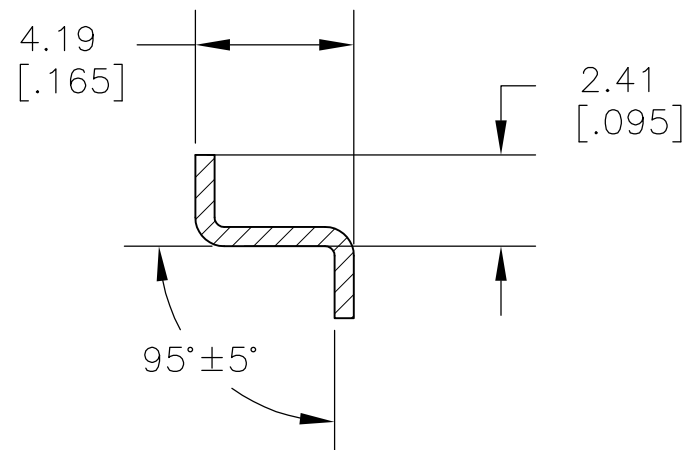
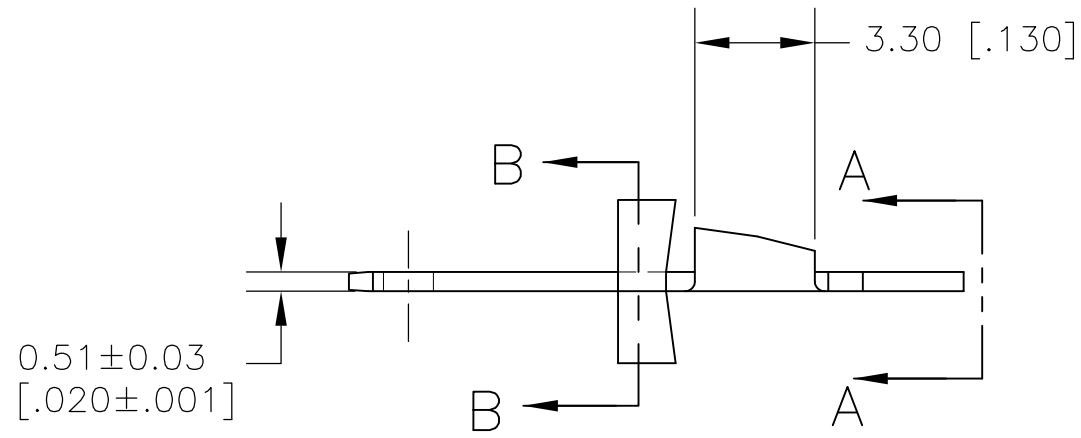

SECTION B-B

- 1 CONTINUOUS STRIP ON REELS
- 2 0.00381 [.000150] MIN TIN PL OVER 0.00254 [.000100] MIN COPPER PL.
- 3 PARTS TO MEET AMP SOLDERABILITY SPEC 109-11-2, MIDLY ACTIVATED ROSIN.
- 4 PRINTED CIRCUIT BOARD THK IS 0.81/2.36 [.032/.093] THK WITH A HOLE DIA OF 1.70/1.60 [.067/.063].
- 5 FINISH LEAD-FREE, MATTE TIN PLATING OVER COPPER OR NICKEL UNDER-PLATING.

|        |          |
|--------|----------|
| 5      | 61968-6  |
| 2      | 61968-1  |
| FINISH | PART NO. |

|  |               |                  |           |                  |                            |           |               |               |       |     |       |     |        |     |              |      |  |
|--|---------------|------------------|-----------|------------------|----------------------------|-----------|---------------|---------------|-------|-----|-------|-----|--------|-----|--------------|------|--|
| THIS DRAWING IS A CONTROLLED DOCUMENT.   |               | DWN              | JR RUTH   | 22FEB01          | <b>STE</b> TE Connectivity |           |               |               |       |     |       |     |        |     |              |      |  |
| DIMENSIONS: MM [ INCHES ]  |               | CHK              | MS FEHER  | 22FEB01          |                            |           |               |               |       |     |       |     |        |     |              |      |  |
| TOLERANCES UNLESS OTHERWISE SPECIFIED:   |               | APVD             | N DEIBERT | 22FEB01          |                            |           |               |               |       |     |       |     |        |     |              |      |  |
| <table border="0"> <tr><td>0 PLC</td><td>± -</td></tr> <tr><td>1 PLC</td><td>± -</td></tr> <tr><td>2 PLC</td><td>± 0.25 [.010]</td></tr> <tr><td>3 PLC</td><td>± -</td></tr> <tr><td>4 PLC</td><td>± -</td></tr> <tr><td>ANGLES</td><td>± -</td></tr> </table> |               | 0 PLC            | ± -       | 1 PLC            |                            | ± -       | 2 PLC         | ± 0.25 [.010] | 3 PLC | ± - | 4 PLC | ± - | ANGLES | ± - | PRODUCT SPEC | NAME |  |
| 0 PLC  | ± -           |                  |           |                  |                            |           |               |               |       |     |       |     |        |     |              |      |  |
| 1 PLC  | ± -           |                  |           |                  |                            |           |               |               |       |     |       |     |        |     |              |      |  |
| 2 PLC  | ± 0.25 [.010] |                  |           |                  |                            |           |               |               |       |     |       |     |        |     |              |      |  |
| 3 PLC  | ± -           |                  |           |                  |                            |           |               |               |       |     |       |     |        |     |              |      |  |
| 4 PLC  | ± -           |                  |           |                  |                            |           |               |               |       |     |       |     |        |     |              |      |  |
| ANGLES   | ± -           |                  |           |                  |                            |           |               |               |       |     |       |     |        |     |              |      |  |
| MATERIAL   | BRASS         | FINISH           | 2         | APPLICATION SPEC | 2.79 [.110] SERIES         |           |               |               |       |     |       |     |        |     |              |      |  |
|  |               | WEIGHT           | -         |                  | SIZE                       | A3        |               |               |       |     |       |     |        |     |              |      |  |
|  |               | CUSTOMER DRAWING |           | SCALE            | 5:1                        | CAGE CODE | 00779         |               |       |     |       |     |        |     |              |      |  |
|  |               |                  |           | DRAWING NO       | G-61968                    |           | RESTRICTED TO | -             |       |     |       |     |        |     |              |      |  |
|  |               |                  |           | SHEET            | 1 OF 1                     |           | REV           | W1            |       |     |       |     |        |     |              |      |  |